

# Mountain Top® Roll

Owner's manual

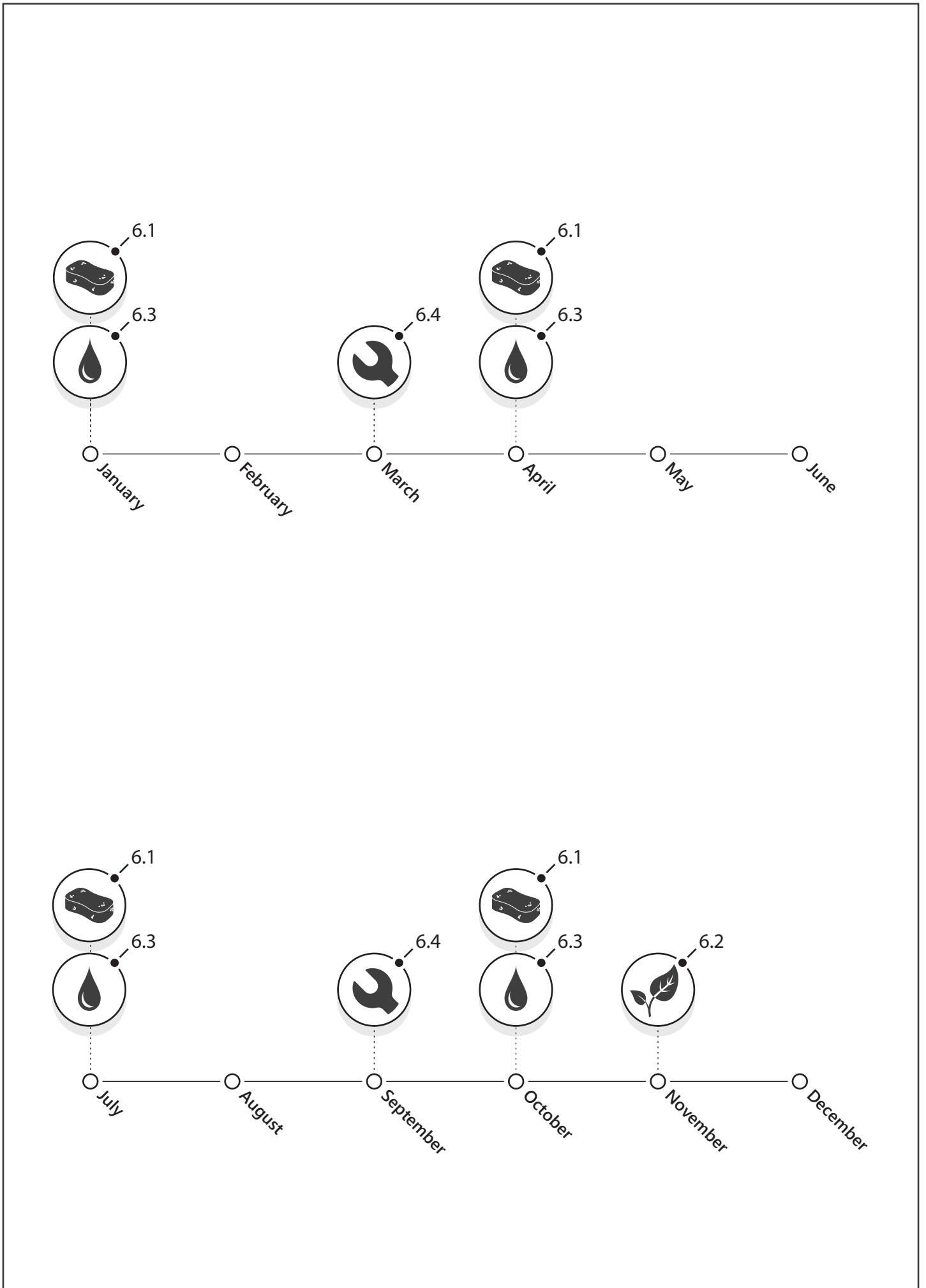

DOWNLOAD PDF



General maintenance calendar

1.	Conditions of use.....	p. 2
2.	Warnings.....	p. 4
3.	Functions.....	p. 5
4.	Release locking system.....	p. 6
5.	Spring adjustment.....	p. 8
6.	Maintenance	
	6.1 General cleaning.....	p. 9
	6.2 Cleaning the canister.....	p. 10
	6.3 Lubrication.....	p. 11
	6.4 Clamps.....	p. 12
7.	Accessories.....	p. 13

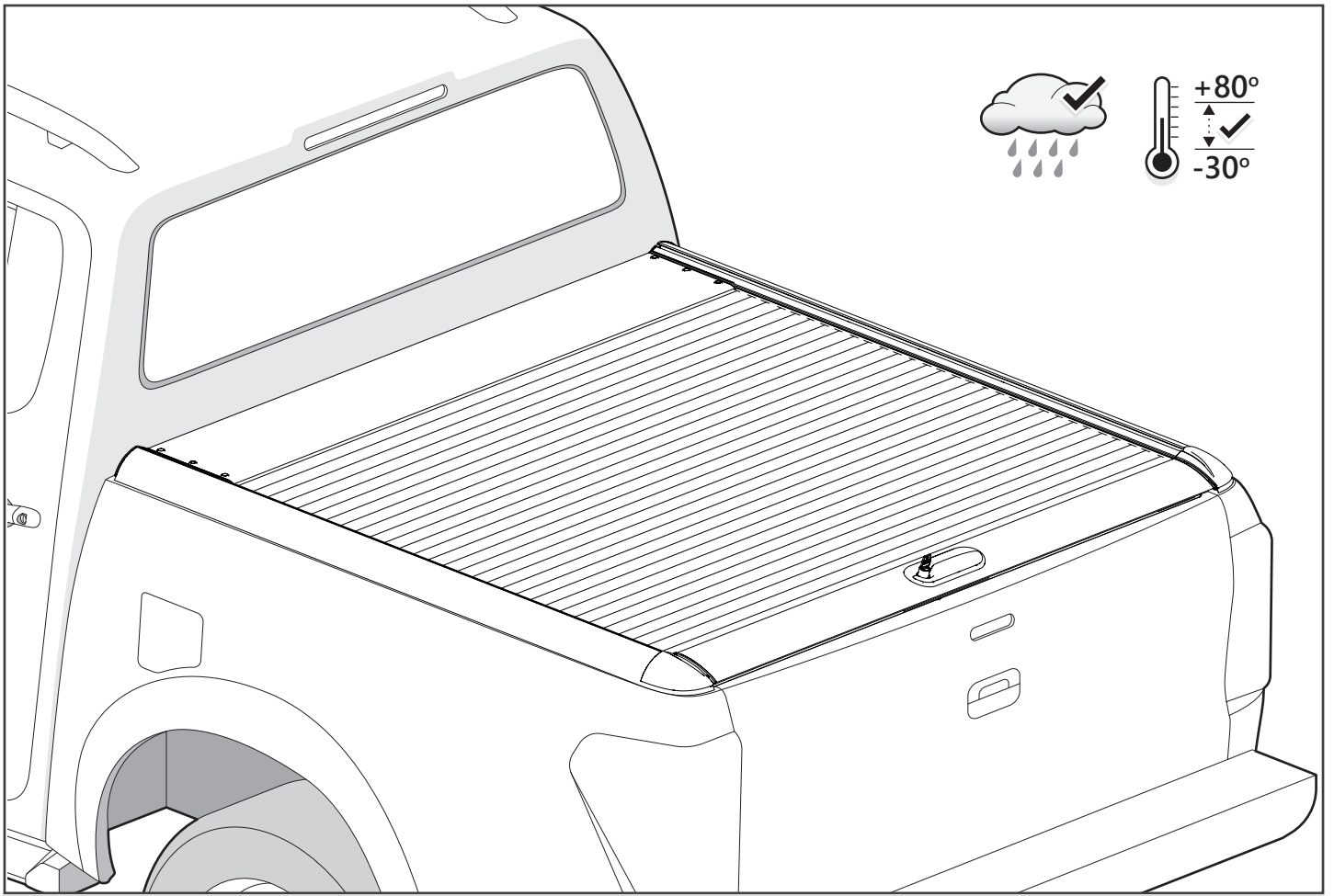

## 1 Conditions of use

- The Mountain Top Roll cover is made of aluminium, plastics, and rubber.
- To ensure a smooth and trouble free operation, it's advised to follow this manual.
- The Mountain Top Roll cover has been designed for normal driving conditions on roads; the design is lightweight and not suitable for extreme usage.
- Temperature range: -30 to +80 degrees Celsius.
- The purpose of The Mountain Top Roll cover is to cover the bed from rain and dirt:
  - Designed to withstand rain water, some water ingress may occur. In the tailgate area there will be water ingress due to lack of sealing.
  - Dust can enter the compartment through various gaps around the tailgate area, other sealings etc.
- The Mountain Top Roll is made of aluminium profiles which heats up and cools down relatively quick according to weather conditions. This can cause condensation on the inside of the profiles and the panels.

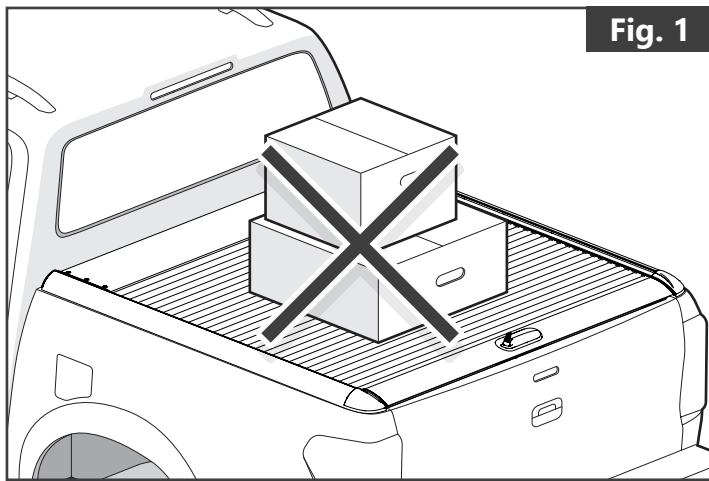

Fig. 1

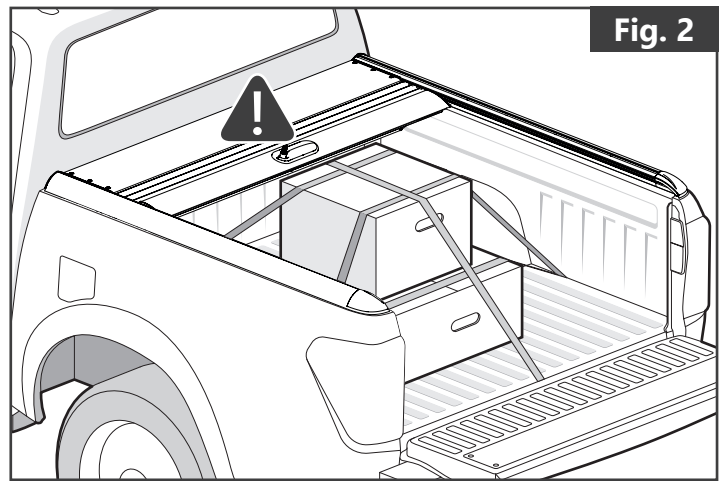

Fig. 2

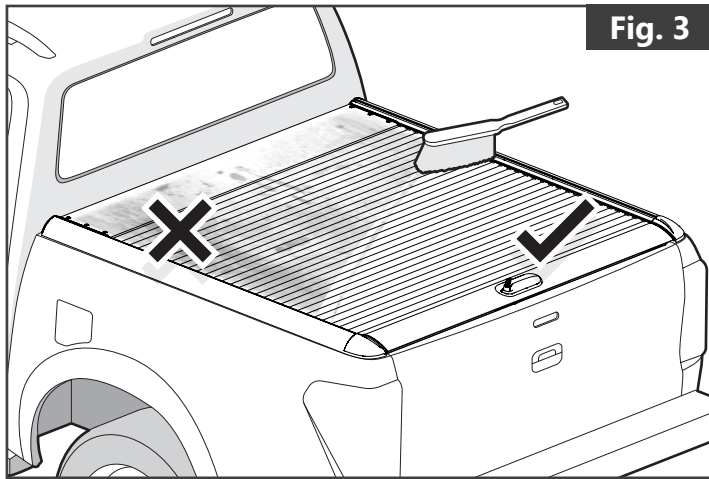

Fig. 3

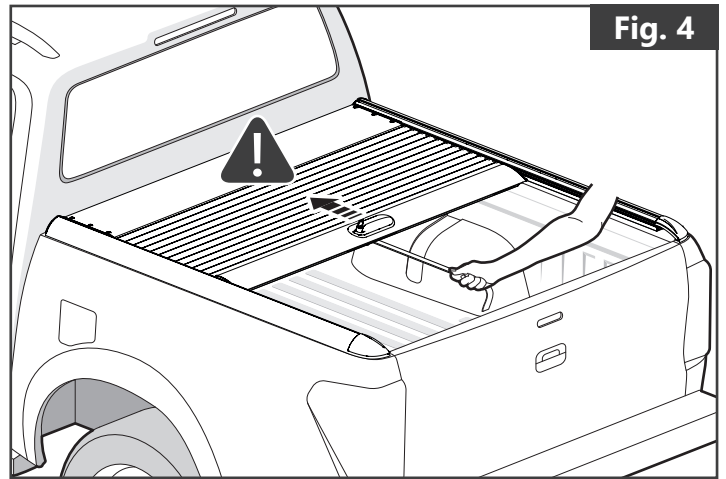

Fig. 4

- The Roll cover is not designed for loading although it can support normal snow loads. No part of it can support any load from cargo or persons and the product might be damaged if somebody stands on it. **(Fig. 1)**
- The Mountain Top Roll is NOT a 100% waterproof product, but offers good protection against the elements. It is weather resistant, meaning that some water penetration is acceptable.
- The pull strap has been designed only for opening and closing the Roll cover. The carabineer and ring will be damaged in case of excessive load.
- Goods in the bed must be secured during transportation to prevent damage on the structural parts of Roll cover (especially the canister). **(Fig. 2)**
- If the Roll cover is closed and has water, snow, ice or dirt on the cover, it might enter into the bed as the cover retracts. To avoid this, clean off the top surface of the cover prior to opening. **(Fig. 3)**
- When opening the cover, the opening should be careful and controlled using the pull strap to prevent the cover from hitting the front with full speed, which it has NOT been designed for. **(Fig. 4)**

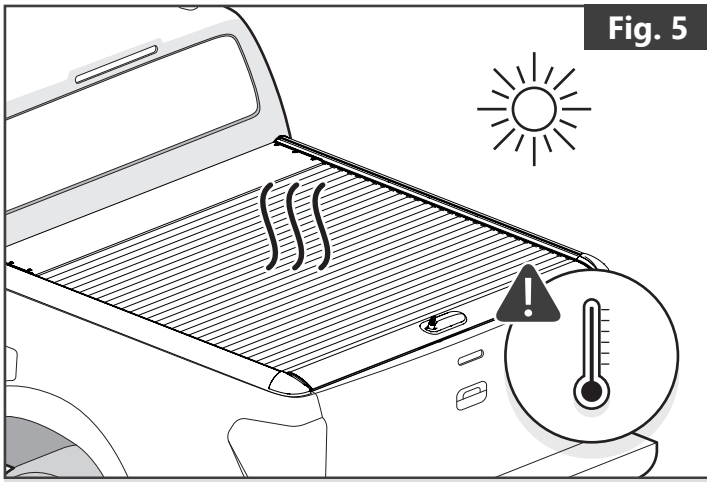

Fig. 5

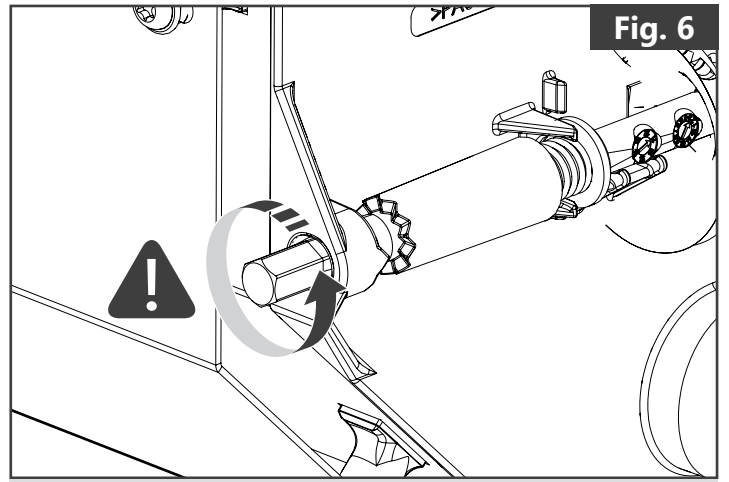

Fig. 6

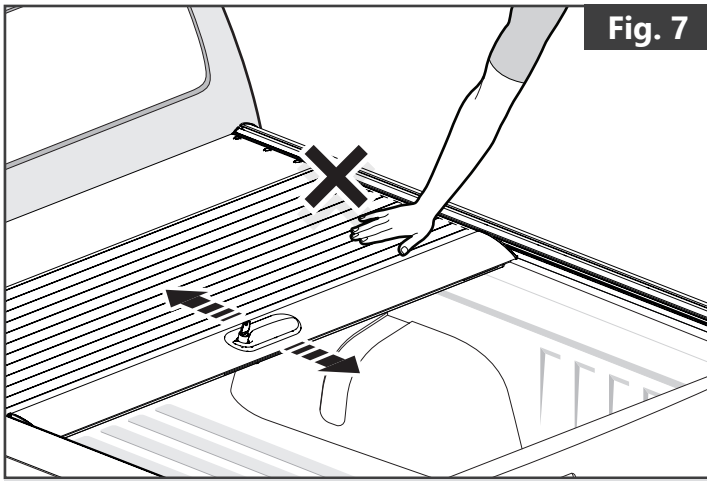

Fig. 7

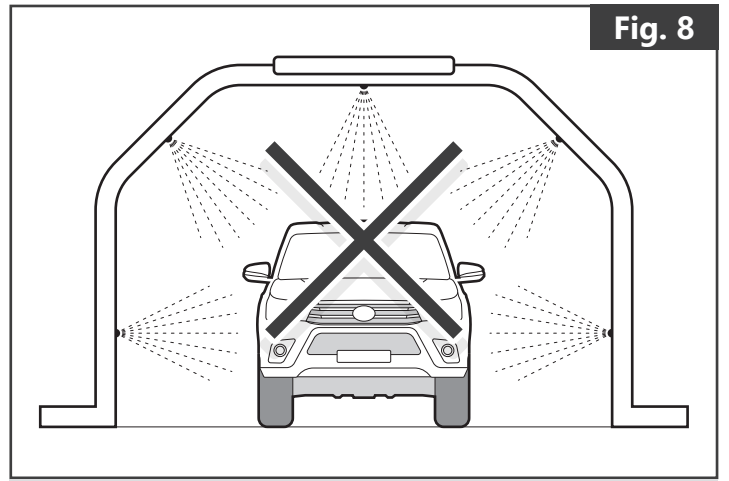
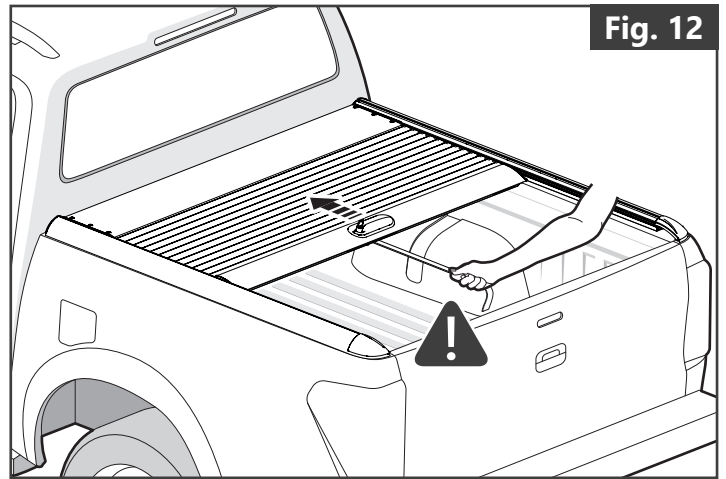
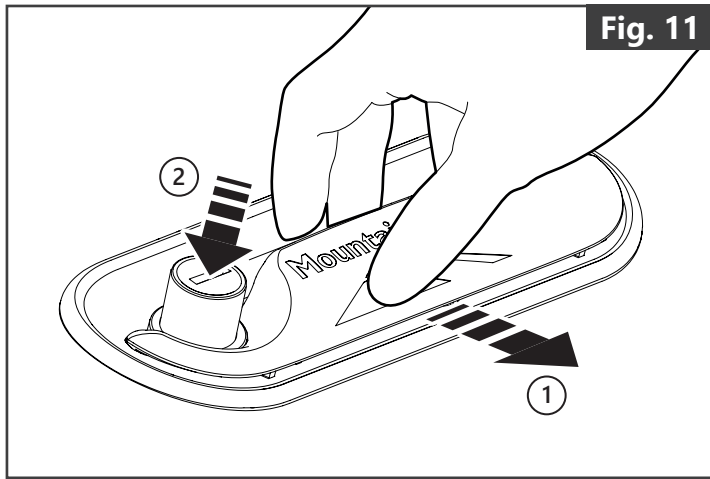
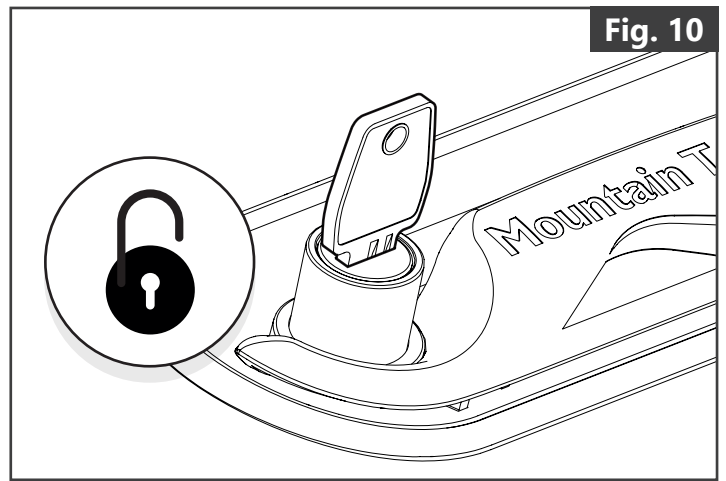
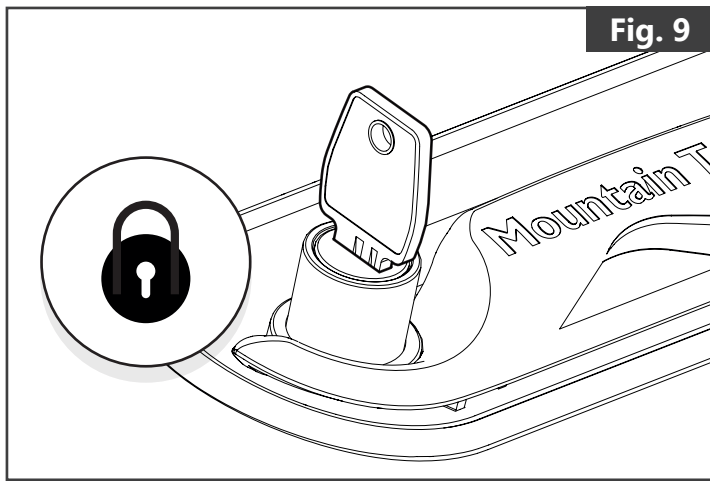

Fig. 8

## 2 Warnings

- Do not drive with persons under the Roll cover.
- Do not allow persons or animals to stay in the bed when the cover is closed.
- Temperatures can be very high under the cover when closed. **(Fig. 5)**
- The pull strap should not be used to tie down cargo.
- Do not disassemble the main shaft from the canister without relieving the spring tension completely (See "Spring adjustment"). **(Fig. 6)**
- Remove fingers from lamellas when opening and closing. **(Fig. 7)**
- We do not recommend washing the Roll cover in a brushless carwash, as the coating may be damaged due to use of chemicals. **(Fig. 8)**
- Wash the Roll cover regularly using normal car shampoo and a soft, lint free cloth or brush.
- If washed in any carwash, or if any chemicals are used on the roll cover, please ensure a max PH value of 8 is used.



### 3 Functions

- To open The Mountain Top Roll cover:
  - Make sure the Roll cover is unlocked (**Fig. 9+10**)
  - Pull back on the handle, and press down on the lock cylinder (**Fig. 11**)
  - Use the pull strap to gently open the Roll cover (**Fig. 12**)
- To move the cover forward to an open position requires use of the locking function, although the cover can be moved rearwards to closing position without operating the locking function.

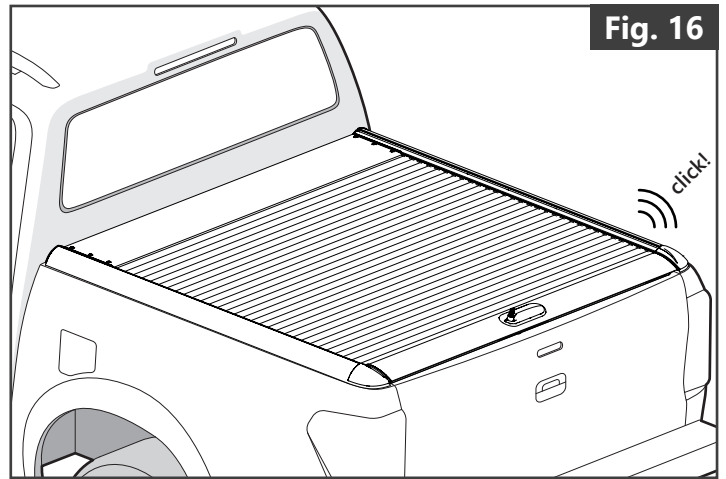
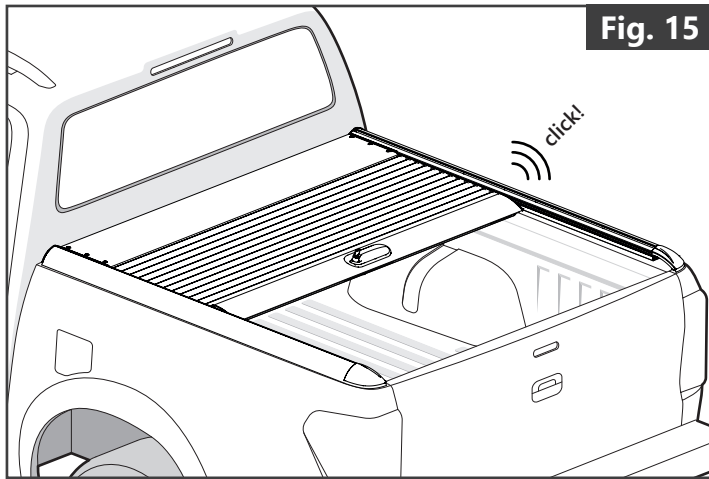
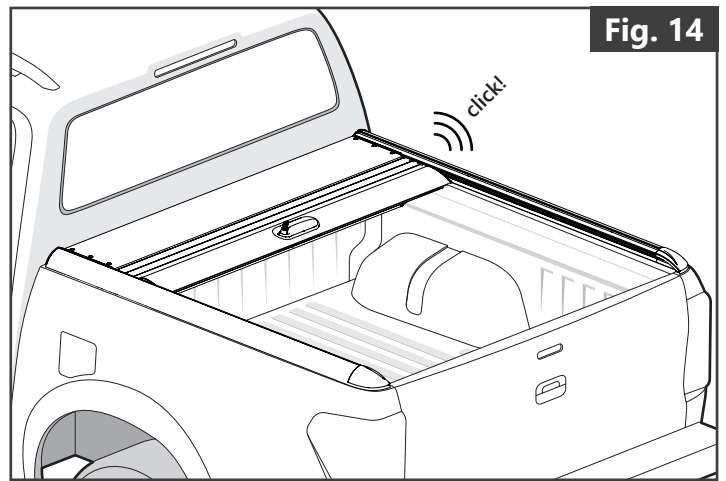
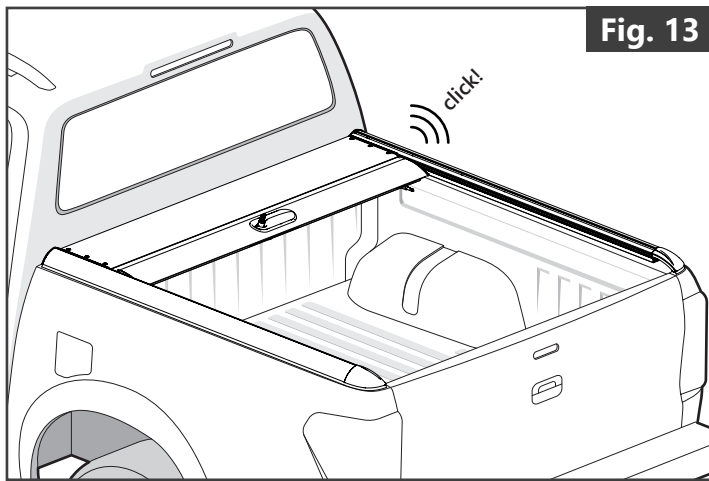

## 4 Release locking system

- The Mountain Top Roll cover features a locking system with multiple locking points along the profiles.
- When the locking system is engaged, the Roll cover will lock in these 4 positions:
  - Fully open. (**Fig. 13**)
  - 2/3 open. (**Fig. 14**)
  - 1/3 open. (**Fig. 15**)
  - Fully closed. (**Fig. 16**)
- To fully open the Roll cover, the locking system must be disengaged.



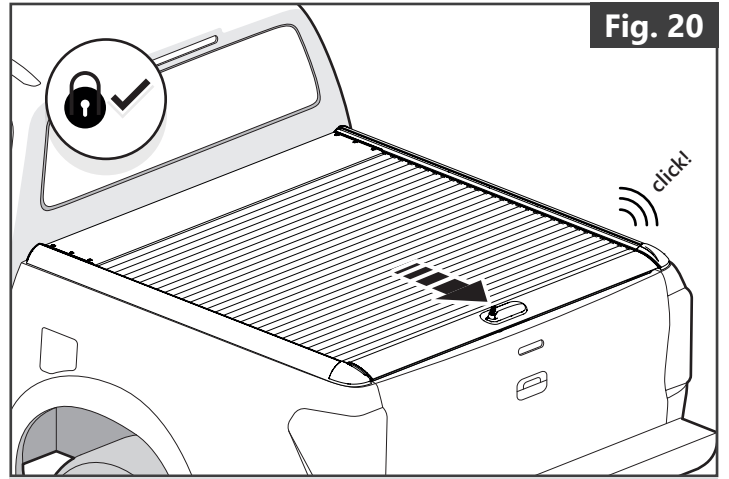
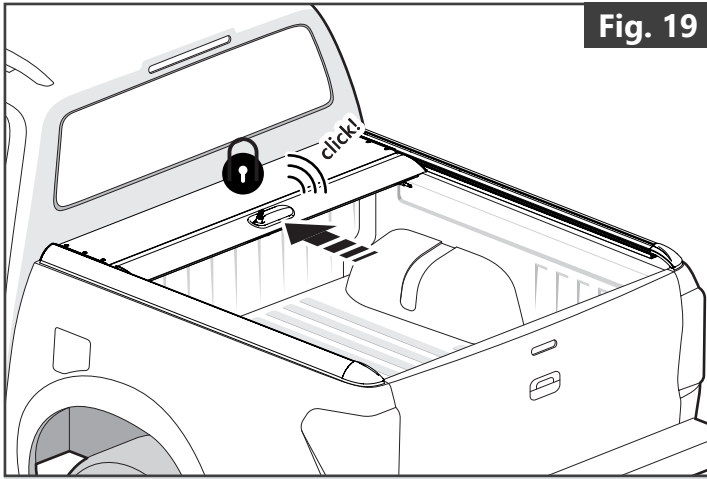
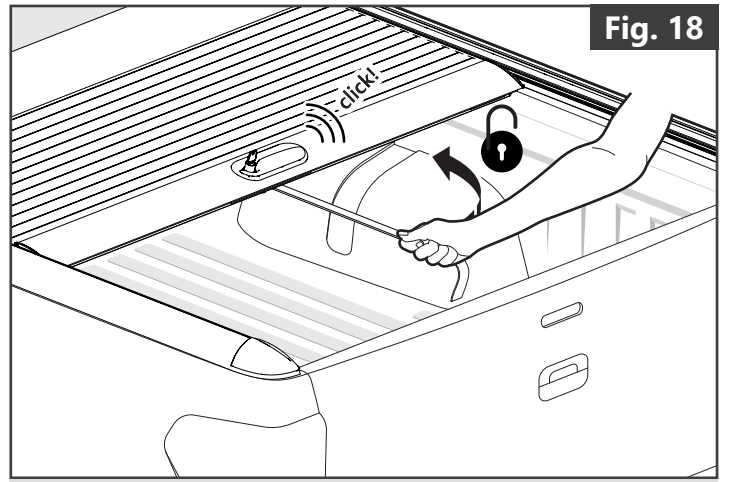
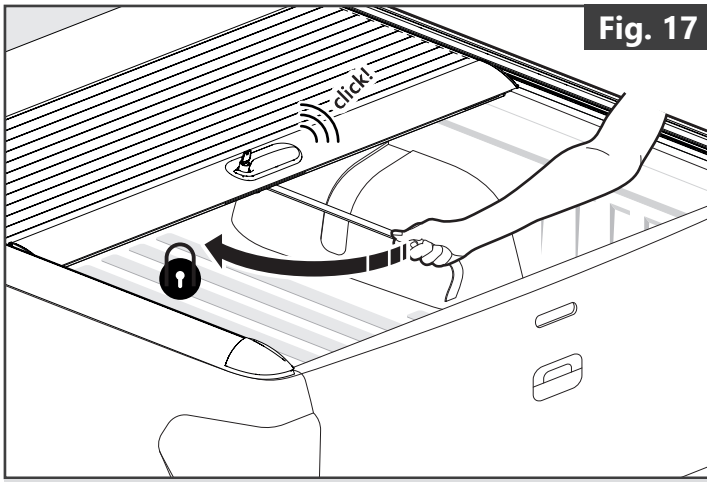

- To toggle the locking system, pull the strap either left (**engage**) or right (**disengage**). (**Fig. 17+18**)
- When the Roll cover is fully opened, a lock activator is automatically triggered, engaging the locking system. (**Fig.19**)
- For the Roll cover to close correctly, the locking system must be engaged before the cover is closed. (**Fig. 20**)

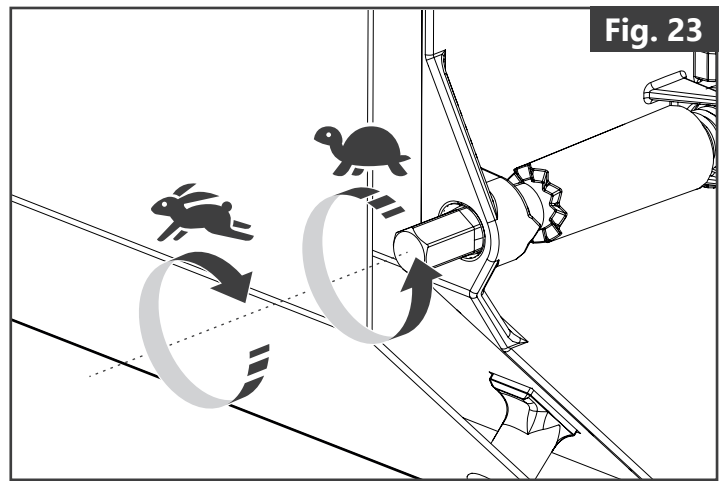
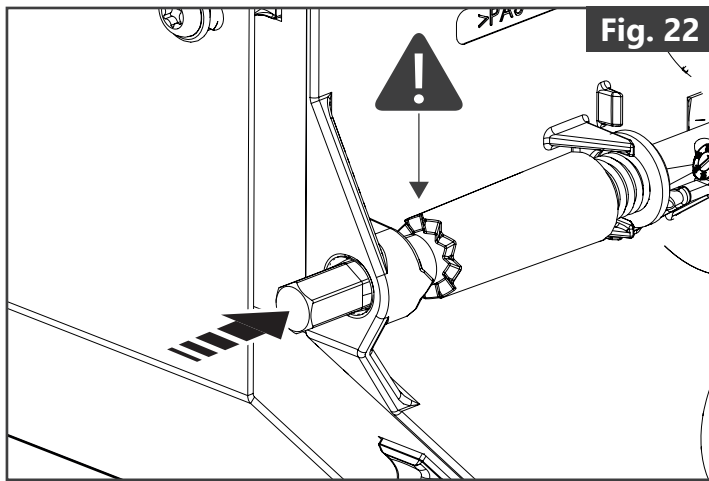
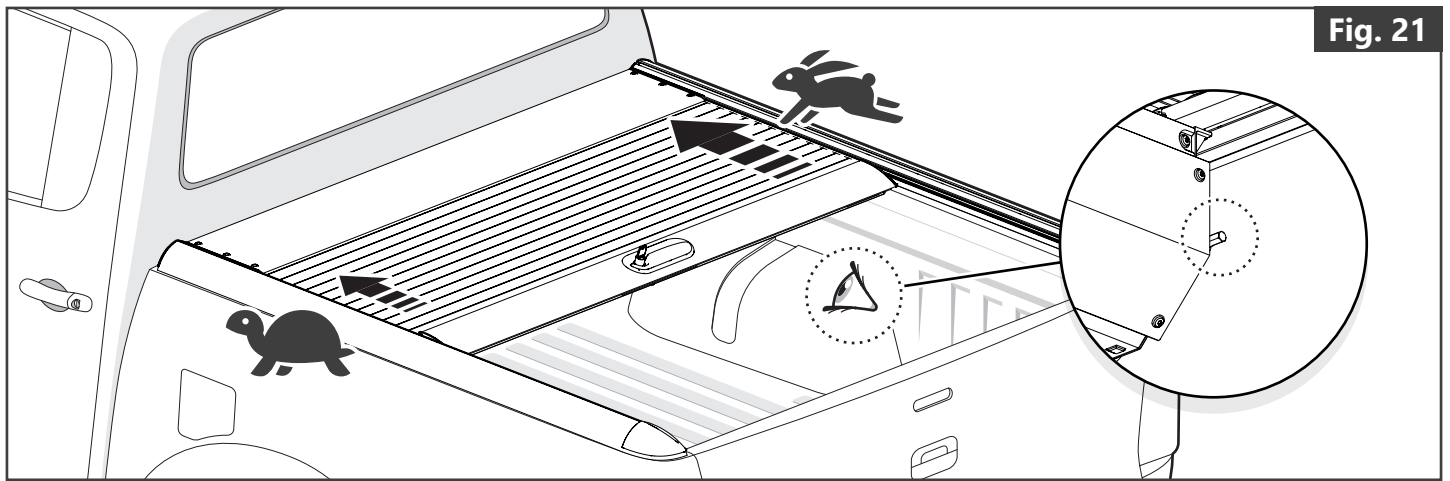

## 5 Spring adjustment

- The main spring is positioned in the main shaft in the canister. The spring tension has been adjusted by delivery and is ready to use.
- Spring tension can easily be adjusted. At the right side of the canister end piece there is a pinion. **(Fig. 21)** To adjust the tension:
  - Press the pinion inward to release the locking mechanism. Use a small wrench with an 8 mm key: **(Fig. 22)**
  - While maintaining pressure on the pinion, adjust clockwise to increase spring tension and make the Roll cover open faster **(Fig. 23)**
  - While maintaining pressure on the pinion, adjust anticlockwise to reduce spring tension and make the Roll cover open slowly **(Fig. 23)**
- **WARNING** - The main spring may cause injury if the canister is opened without relieving the spring tension.
- **WARNING** - Do not tighten the spring with a force higher than 7 Nm, and no lower than 5 Nm, as the spring might get damaged.

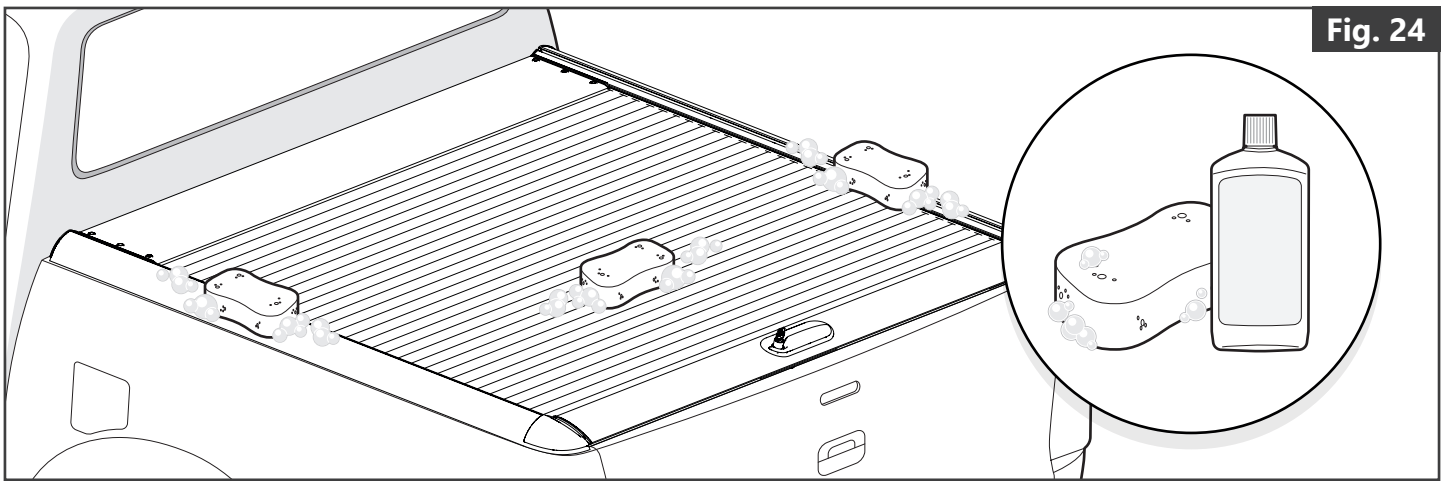

Fig. 24

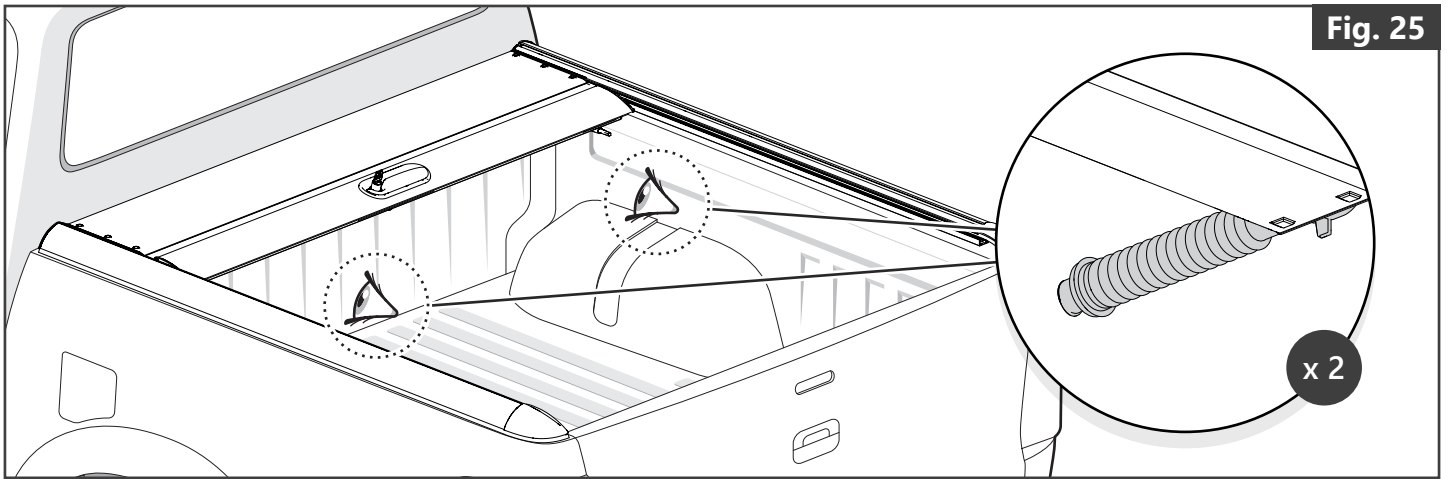
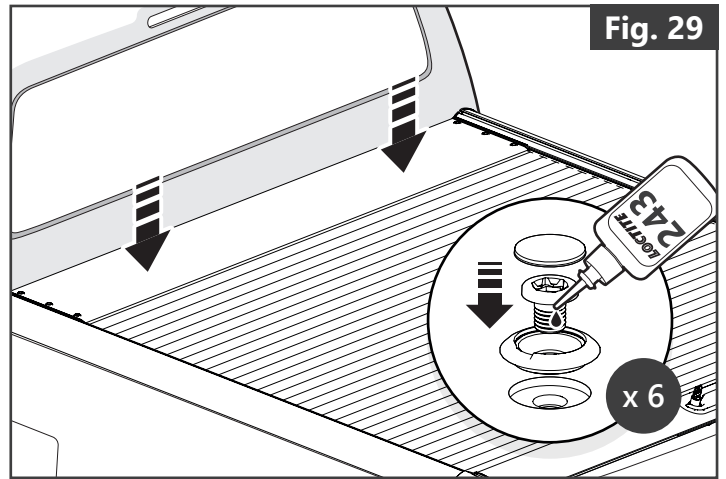
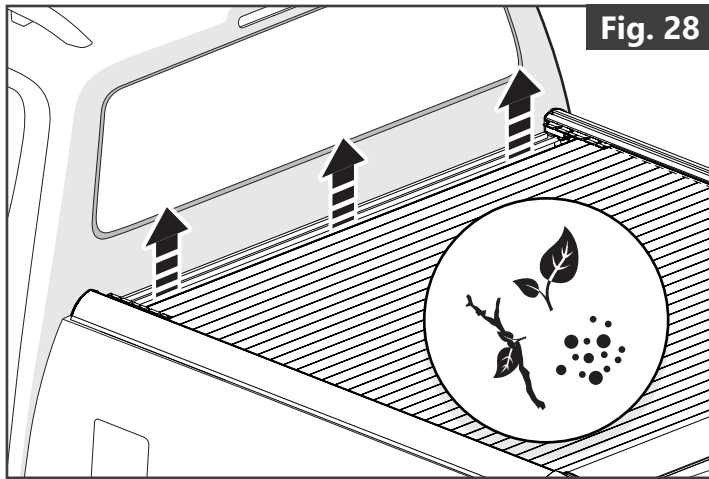
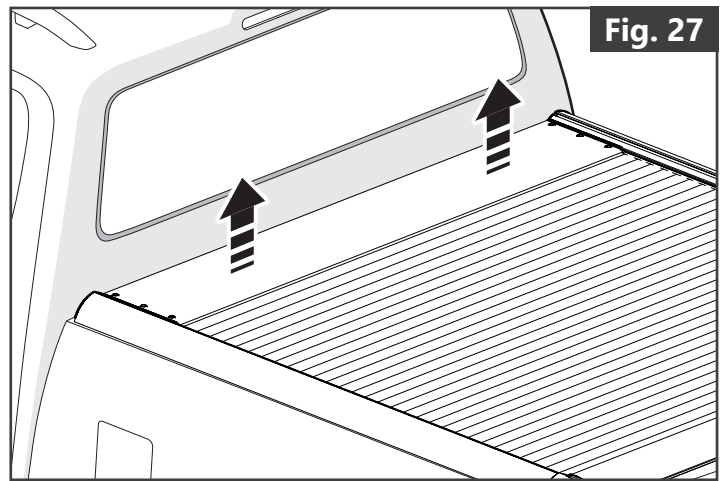
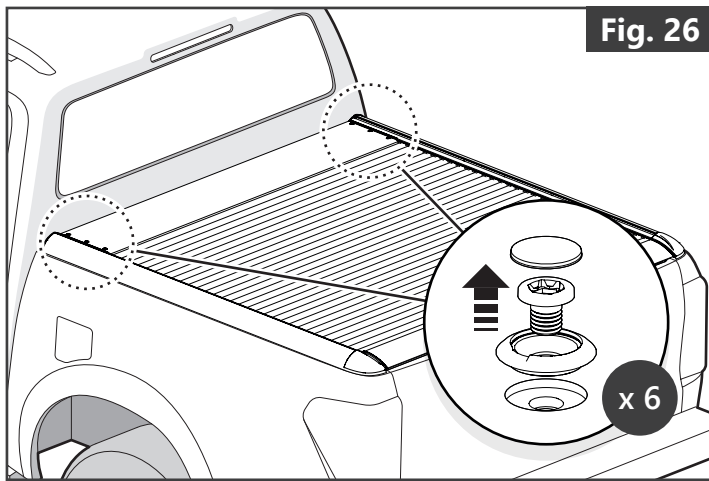

Fig. 25

## 6.1 General cleaning

- The Roll cover should be cleaned on a regular basis using water with normal car shampoo.  
(Fig. 24)
- Drains should be cleaned often to assure proper function of water management  
(Fig. 25)
- When cleaning, use a soft, lint free cloth or brush. Rinse soap foam off thoroughly with fresh water, and dry with a clean cloth. It is vital that any other chemicals such as petrol, strong alkaline or acid are NOT used on the surface.
- Do not use abrasive cleaning tools such as steel wool, hard brushes, abrasive scourers, as these may damage the coating surface and change the color or gloss levels of the finish.



## 6.2 Cleaning the canister

- The canister should be cleaned at least once a year removing dirt and debris. The lid over the canister needs to be removed for this operation and should be carefully reassembled. Take care not to lose the plastic screw caps
  - Remove the 6 screws on the lid. Take care not to lose them. **(Fig. 26)**
  - Remove the lid. **(Fig. 27)**
  - Remove dirt and debris from the canister. **(Fig. 28)**
  - Reassemble the lid, using e.g. a drop of **Loctite 243** and a torque wrench at **1,8 Nm**. **(Fig. 29)**

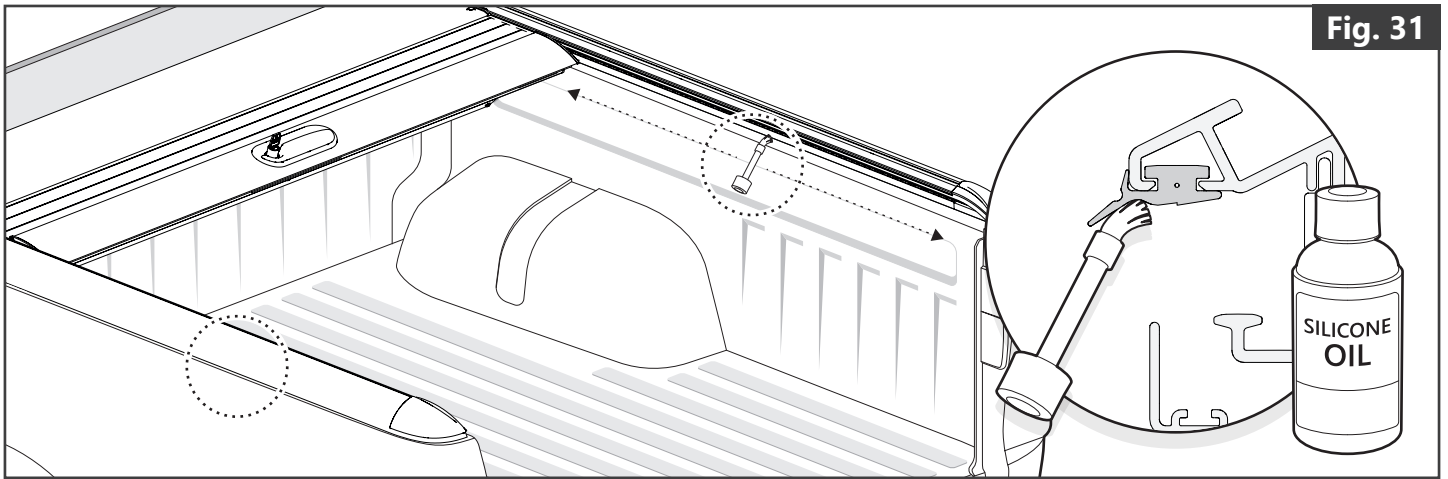
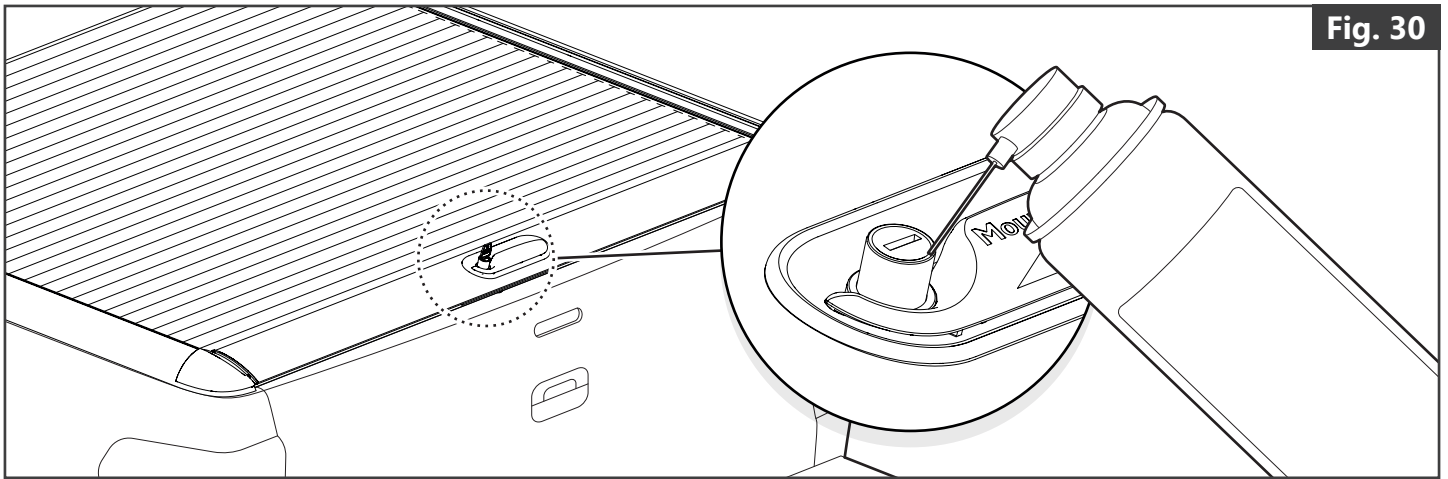

## 6.3 Lubrication

- The lock should be lubricated regularly using a suitable lock lubricant (e.g. Würth lock spray), or similar. **(Fig. 30)**
- Seals and side profiles should be cleaned and lubricated regularly using silicon (e.g. Würth Silicon Oil), or similar. **(Fig. 31)**

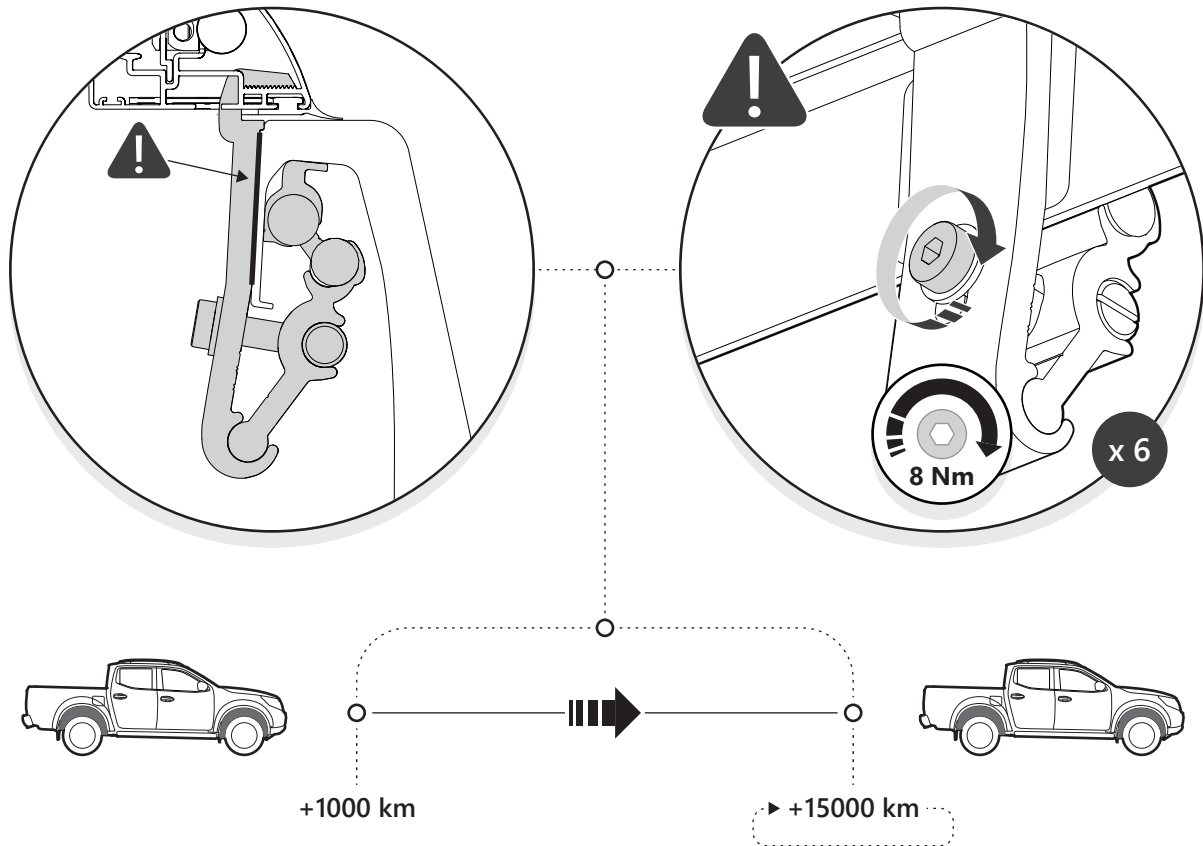
**Fig. 32**

## 6.4 Clamps

- The clamps should be positioned correctly, and re-tightened to 8 Nm (**Fig. 32**), at these intervals :
  - 1000 km after first use.
  - Check all screw connections and fastenings of rollcover, tighten and/or readjust as necessary and check again at regular intervals.

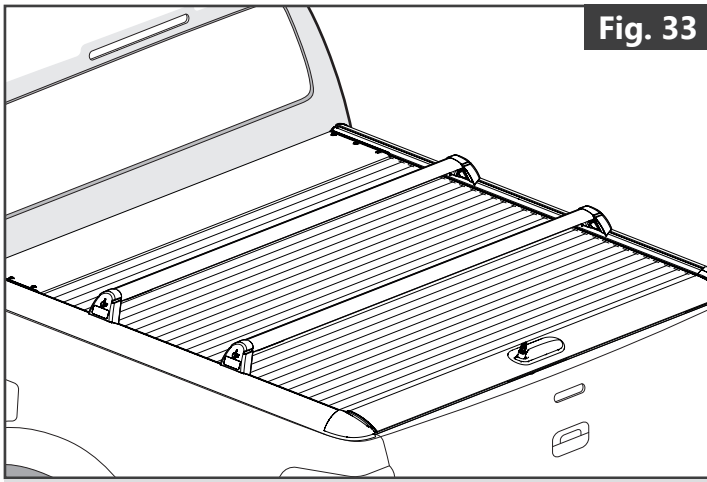

**Fig. 33**

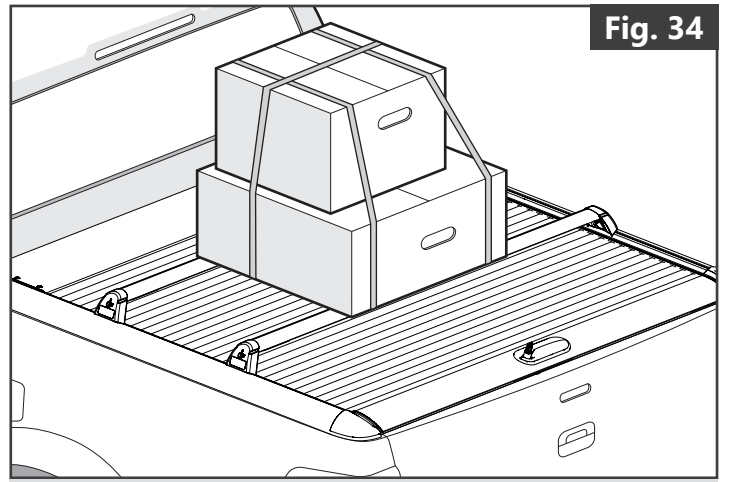

**Fig. 34**

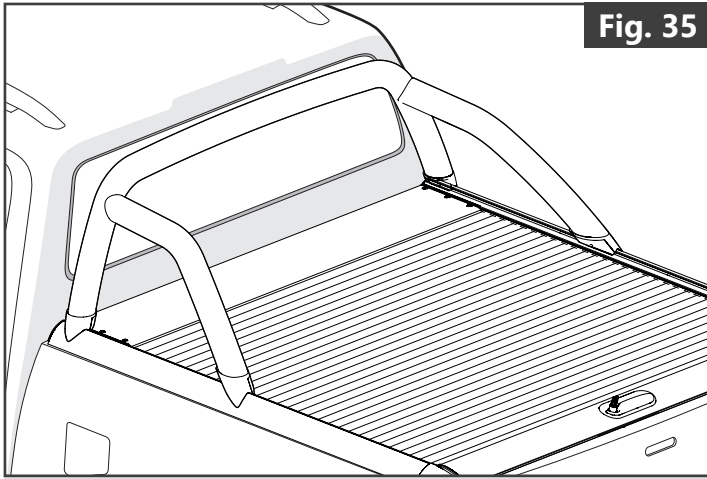

**Fig. 35**

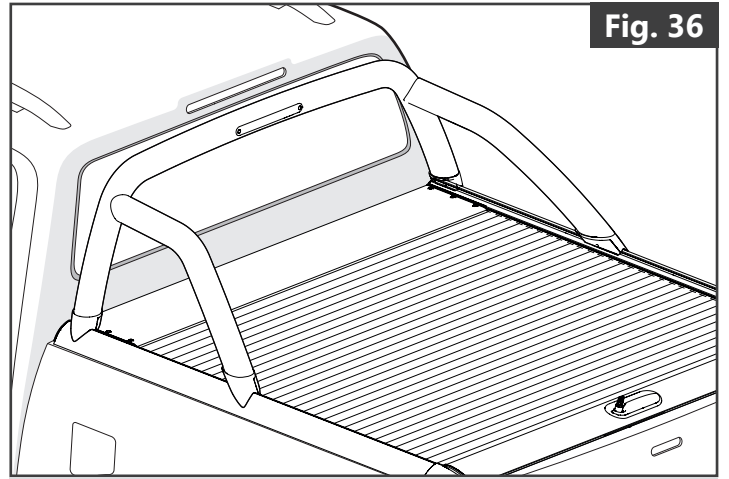

**Fig. 36**

## **7** Accessories

- Mountain Top Cargo Carrier (**Fig. 33**)
  - Combined load capacity of 75 Kg (including bars) (**Fig. 34**)
  - Lockable end-caps
  - Moveable
- Mountain Top Sports Bar
  - Available in 2 versions; with and without brakelight. (**Fig. 35+36**)



Customer Service	+45 4810 2950 (08:00 - 16:00 CET)
Fax	+45 4810 2960
Support	<a href="mailto:info@mountaintop.dk">info@mountaintop.dk</a>
Website	<a href="http://www.mountaintop.dk">www.mountaintop.dk</a>
Address	Pedersholmparken 10, 3600 Frederikssund, Denmark